

## 3-PART SPECIFICATION

### BICYCLE STORAGE LOCKERS

**DIVISION 12 - FURNISHINGS**  
**12 93 00 Site Furnishings**  
**12 93 14 Bicycle Lockers**

---

#### PROPARK VT "VIEW-THRU" BICYCLE LOCKERS

These specifications were current at the time of publication, but are subject to change at any time without notice. Please confirm the accuracy of these specifications with the manufacturer and/or distributor prior to installation.

**Part 1            General**

**1.1                SECTION INCLUDES**

- A. High Strength Sheet Molding Compound (HSMC) plastic composite, modular Bicycle Storage Lockers and hardware.

**1.2                SUBMITTALS FOR REVIEW**

- A. Product Data: For each type of product indicated.
- B. Samples: For each type of finish indicated
- C. Product Layout Drawings: For layout options and site dimensions.

**1.3                SUBMITTALS FOR INFORMATION**

- A. Manufacturer information: "Installation Guide and Owner's Manual - ProPark Series".
- B. Maintenance Data: Included in Owner's Manual
- C. Certifications: For exterior HSMC Molded material, certified by manufacturer.
- D. LEED Qualified Credits:

CATEGORY	SUB CATEGORY	CREDIT
Sustainable Sites	Alternative Transportation - Bicycle Storage	SS Credit 4.2
Innovation in Design	Innovation in Design	ID Credit 1

Innovation in Operations	Innovation in Operations	IO Credit 1
Materials & Resources	Recycled Content	MR Credit 4
Smart Location & Linkage	Bicycle Network & Storage	SSL Credit 4
Neighborhood Pattern & Design	Regional Materials	NPD Credit 5
Neighborhood Pattern & Design	Transit Facilities	NPD Credit 7
Neighborhood Pattern & Design	Transportation Demand Management	NPD Credit 8

**1.4 QUALITY ASSURANCE**

- A. Products: Manufactured to ISO 9000 or ISO 14000 requirements.
- B. Manufacturer Qualifications A company specialized in the manufacture of fiberglass reinforced plastic/SMC composite.
- C. Conformance: Conform to Class I Bicycle Parking Facilities requirements.

**1.5 DELIVERY, STORAGE AND HANDLING**

- A. Inspect bicycle locker components on delivery for carrier damage. Store bicycle locker components in original undamaged packaging in an area sheltered from weather until ready for installation. Inspect bicycle locker components prior to setup and installation.

**1.6 WARRANTY**

- A. Warranty covers materials and workmanship
- B. Warranty Period:
  - 1. Five (5) years from date of invoice for all manufacturer's non-HSMC components.
  - 2. Fifteen (15) years from date of invoice for failure of HSMC composite material with exterior coatings due to corrosion.

- C. Warranty period for mechanical locks: Two (2) years from date of invoice.
- D. Warranty does not cover improper installation, neglect, misuse, accidents, vandalism, natural disasters, fire, or acts of war or terrorism.

## **Part 2 Products**

### **2.1 DESIGN CRITERIA & CONSTRUCTION**

- A. Bicycle Lockers System: Designed with six (6) major replaceable components that provide an interlocking locker system that easily accommodates expansion. The lockers provide a sturdy enclosure, adequate security and capacity within for storing all conventional bike sizes. They are aesthetically pleasing, and are weather and graffiti resistant. Require less shipping and storage area than assembled lockers.
- B. Vertical / Horizontal Members, Channel:
  - 1. Modular / Interlocking Design: Bicycle lockers with interlocking design for configuration into integrated systems is required.
  - 2. Material: Hot compression molded fiberglass reinforced plastic (HSMC) using polyester resin.
  - 3. Construction: 2 inch deep reinforced ribs, interlocking ends and fastening points molded-in with concealed fasteners.
- C. Top Panels: Fiberglass HSMC top panels provide high mechanical strength and rigidity, high surface quality, reduced heat build-up, and rust or denting resistance.
  - 1. Material: Hot compression molded fiberglass reinforced plastic (HSMC) using polyester resin.
  - 2. Construction: Crowned stipple textured surface with 2 inch deep reinforced ribs and flush construction parallel to the Door Panel.
- D. End Panels: Deep impressions to stiffen bottom and contoured corners.
  - 1. Material: Thermoformed high-impact ABS sheet
  - 2. Construction: Recessed center to accept Polycarbonate 1/4 inch x 23 inches x 60 inches transparent panel.
- E. Design bicycle storage assemblies and provide clearances that will allow for installation tolerances and free unobstructed access to users.
- F. Assemble units with concealed fasteners or locate fasteners in areas inaccessible when locker units are closed.
- G. Doors: Manufactured to same material standards as the locker body and include recessed tamper proof door jambs. Doors should open and close easily without being forced.
  - 1. Integrated full length Latching System to help prevent door prying
  - 2. Built-in Rotary type mechanical locking mechanism (other types are available)

- 
3. Material: Hot compression molded fiberglass reinforced plastic (HSMC) using polyester resin.
  4. Construction: Crowned stipple textured surface with 2 inch deep reinforced ribs and flush construction parallel to the Top Panel.
  5. Polycarbonate 1/4 inch X 11 inches X 11 inches viewing port.
- H. Door Locks: Pop-out T-Handle Vending type mechanism with high security removable plug type cylinder lock for T-handle, UL 437 listed to exceed one million cycles operational testing. Locks are recessed and mounted internally for security.
1. Key each locker door cylinder separately and supply (3) keys with each.
  2. All lock cylinders shall be completely re-keyable to new combinations.
  3. Contractor to label door keys with corresponding locker door number per manufacturer's requirement
  4. Lock Cylinders: Pick-resistant, high security type with angled key cuts and rotating disc tumblers as manufactured by Albo Security Locks, Inc. (Executive Series) or approved equal.
  5. T-Handle Assembly: NAMA Rotary Vending Standard countersunk within door face.
  6. Furnish locking system in a factory restricted key selection for which uncut keys are not made available from the manufacturer's factory or any other source by normal distribution methods. All key duplication must be done at the factory or authorized service center upon properly authorized signature.
- I. Identification: Include numerical identification aluminum plate with 3/4 inch high photo etched numbers mounted behind stainless steel escutcheon plate on locker door. Locker doors shall be labeled sequentially from (#) [ \_\_\_\_\_ ] to (#) [ \_\_\_\_\_ ] as directed by Owner.
- J. Roof: Passive draining, having either channels or crowned top panels to remove water.
- K. Leveling Brackets: Vertical adjustment of four (4) inches
1. Concealed adjustable leveling brackets provided as integral component of framework.
- L. Anchors: Securely attach lockers to mounting surface, where specified, on inside of locker.
1. Anchoring system shall be removable to enable lockers to be relocated if necessary.
  2. Anchors and Fasteners to be structurally stressed not more than 50 percent of allowable stress when maximum loads are applied.
- M. Hinge: Concealed, full length, piano hinge, corrosion resistant finish, 14 gauge steel with stainless steel rod. Pop-riveted attachment is not allowed.
- N. Partitions: For dividing lockers into two compartments and separating lockers.
1. Clear Polycarbonate panels for full view-thru.



2. SMC Composite panel (optional).
3. Perforated metal panels (optional).
4. Custom Panels (optional).
5. Diagonal "Divider" Partition not required (Single-Entry).

## 2.2 BICYCLE STORAGE LOCKERS DESCRIPTION

A. Series: CycleSafe ProPark **See "Locker Data Sheet" for ordering**

B. Models: Single-Tier (1-2) bike capacity

1. Door-View: VT, windows in door and sides.

Access Type:		Starter #	Adder #
2. Double-Entry: two-door access	(M02)	10007	10056
3. Single-Entry: one-door access	(S01)	10043	10045

C. Locker Dimensions:

1. Height: 4 feet, 2 1/2 inches.
2. Width: (Starter) 3 feet, 6 inches; (Adder) 3 feet, 2 inches
3. Depth: 6 feet, 5 1/2 inches.
4. Row Length: Varies depending upon banking configurations.

D. Bicycle Parking Spaces: Locker Capacity

1. Two-door, double ended access lockers: Two (2) triangular interior spaces per two-door locker unit to be no less than forty-six (46) inches high, seventy-two (72) inches deep, thirty-one (31) inches wide at opening and six (6) inches wide at rear.
2. One-door, single ended access lockers: One (1) rectangular interior space per single-door locker unit to be no less than forty-six (46) inches high, seventy-two (72) inches long and thirty-one (31) inches wide at opening.

## 2.3 ACCESSORIES

A. Swing-Handle Latch with stainless steel bracket for utilizing 3/8" thick Padlock or standard 3/4" maximum thickness bicycle U-Lock. Mfr. # 10720.

B. Electronic (Keyless) Door Access Locker Management (contact manufacturer for information and specification details).

1. Keypad and Key Entry: Trilogy DL6100. Mfr. # 15601.
2. Keypad, Key, Proximity: Trilogy PDL6100. Mfr. # 16500.

C. Master keys will be sent by registered mail or UPS AOD (acknowledgement of delivery) from factory directly to the Owner (optional) .

D. Locker Door Identification Number Plates: Manufacturer's standard photo etched aluminum plate, concealed mounting, sequentially numbered with black numbers or letters of at least 3/4 inch (19mm) high. Mfr. # 10703.

- E. Lock Weather Shield: to protect lock and T-Handle from moisture/freezing. Mfr. # 10792.
- F. End Panel Options:
  - 1. View-Thru polycarbonate window: for security. Mfr. # 10964.
  - 2. Perforated metal panel punched bike logo (optional) others (custom).
  - 3. Bike logo silhouette vinyl sticker. Mfr. # 19915
- G. Coat Hooks: partition mounted for hanging personal items. Mfr. # 10791.
- H. Door-Mounted Storage Bin: for non-view thru models only. Mfr. # 10789.
- I. LED Cabin Lights: Mfr #10788.
- J. Poster Grip Snap-in Frame for recessed display side panel, **[24 inch by 60 inch. Mfr # 19901]** and non-recessed **[44 inch by 72 inch. Mfr # 19905]**.
- K. Floor Plate: One per bike space. Mfr. # 10671.
- L. Blue 2-3/8 inch x 4-5/8 inch Bike Parking Decal: Mfr # 10709.
- M. Door Check / Holdback Kit: for propping door open to allow unrestricted access. Mfr. # 10635.
- N. Key Safe: Mechanical key storage box with programmable coded access. Mfr. # 11680.

## 2.4 FINISHES

- A. Manufacturer's factory applied oven baked on, semi-gloss stipple texture finish.
- B. Bicycle locker finish: Exterior coated with Industrial grade two-part acrylic aliphatic polyurethane finish for maximum UV protection and graffiti cleaning resistance (ASTM Type 5 Industrial Maintenance Coating) (PPG PITTHANE® ULTRA or equal).
- C. Locker Color: [**"Sandstone" and "Taupe"; manufacturer standard color.**] [**\_\_\_\_\_ optional color.**] and custom colors also available.

## Part 3 Execution

### 3.1 INSTALLATION

- A. Where installation on concrete is specified, install lockers on minimum 4 inch thick concrete slabs, sloped to provide drainage (maximum 2 degrees). For other improved surfaces, such as pavers or asphalt, contact the Manufacturer for alternate installation procedures.
- B. Fasten to concrete slab or improved surfaces with 5/16 inch RedHead style expansion anchors (furnished).

- C. Set plumb and aligned. Level lockers true to plane with leveling plates and shims.
- D. Field alteration of doors and frames to accommodate field conditions is prohibited.
- E. Adjust doors, latching bar fastening screws, and hardware to operate smoothly, easily, properly, and without binding.

**END OF SECTION**

## CycleSafe {ProPark} Series Bicycle Locker {Data Sheet}

Part #	Model & Option Description				{Examples}	
	SM	DV	SV	VT	LB	KG
SM-S01	Standard Model + (1) Door = (1-2) Bike Capacity				450	204
SM-M02	Standard Model + (2) Doors = (2) Bike Capacity				760	345
DV-M02	Door-View + (2) Door Access = (2) Bike Capacity				1120	508
SV-M04	Side-View + (4) Door Access = (4) Bike Capacity				1350	612
VT-M06	View-Thru + (6) Door Access = (6) Bike Capacity				1740	789
DT/SM-M24	Double-Tier + (24) Doors = (24) Bikes Capacity				1970	894

Part Number	(2) Door Model / Number of Bicycles				Shipping Weight	
	SM	DV	SV	VT	LB	KG
M02	02	02	02	02	450	204
M04	04	04	04	04	760	345
M06	06	06	06	06	1120	508
M08	08	08	08	08	1350	612
M10	10	10	10	10	1740	789
M12	12	12	12	12	1970	894
M14	14	14	14	14	2280	1034
M16	16	16	16	16	2590	1175
M18	18	18	18	18	2900	1315
M20	20	20	20	20	3310	1501
M22	22	22	22	22	3590	1628
M24	24	24	24	24	3870	1755

Part Number	(1) Door Option / Number of Bicycles				Shipping Weight	
	SM	DV	SV	VT	LB	KG
S01	01	01	01	01	393	178
S02	02	02	02	02	646	293
S03	03	03	03	03	949	430
S04	04	04	04	04	1122	509
S05	05	05	05	05	1455	660
S06	06	06	06	06	1628	738
S07	07	07	07	07	1881	853
S08	08	08	08	08	2134	968
S09	09	09	09	09	2387	1083
S10	10	10	10	10	2740	1243
S11	11	11	11	11	2963	1344
S12	12	12	12	12	3186	1445

Model	Name	Description	Row Length	
			IN	CM
SM	Standard	No Windows	43	109
DV	Door-View	Windows in Doors "Only"	81	206
SV	Side-View	Windows in Sides "Only"	119	302
VT	View-Thru	Windows in Doors & Sides	157	399
DT	Double-Tier	Stacked Lockers & Spacers	195	495
<b>M02 Locker Dims are 50-1/2" OAH x 42" OAW x 77-5/8" OAL</b>				

Part Number	Model DT/	Shipping Weight		Row Length	
		LB	KG	IN	CM
M04	04	912	414	43	109
M08	08	1544	700	81	206
M12	12	2276	1032	119	302
M16	16	2748	1246	157	399
M20	20	3540	1605	195	495
M24	24	4012	1820	233	592
M28	28	4644	2106	271	688
M32	32	5276	2393	309	785
M36	36	5908	2680	347	881
M40	40	6740	3057	385	978
M44	44	7312	3317	423	1074
M48	48	7884	3576	461	1171

Part Number	Model DT/	Shipping Weight		Row Length	
		LB	KG	IN	CM
S02	02	798	362	43	109
S04	04	1316	596	81	206
S06	06	1934	877	119	302
S08	08	2292	1040	157	399
S10	10	2970	1347	195	495
S12	12	3328	1510	233	592
S14	14	3846	1745	271	688
S16	16	4364	1980	309	785
S18	18	4882	2214	347	881
S20	20	5600	2540	385	978
S22	22	6058	2748	423	1074
S24	24	6516	2956	461	1171

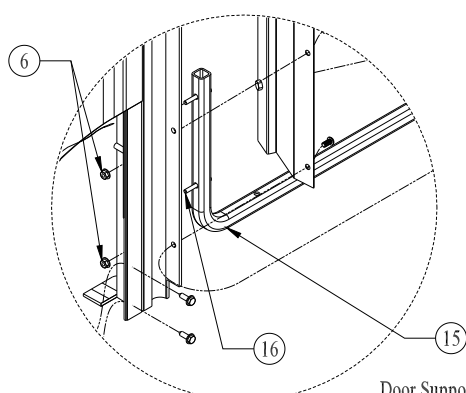
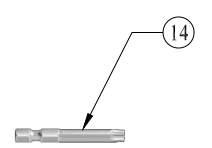
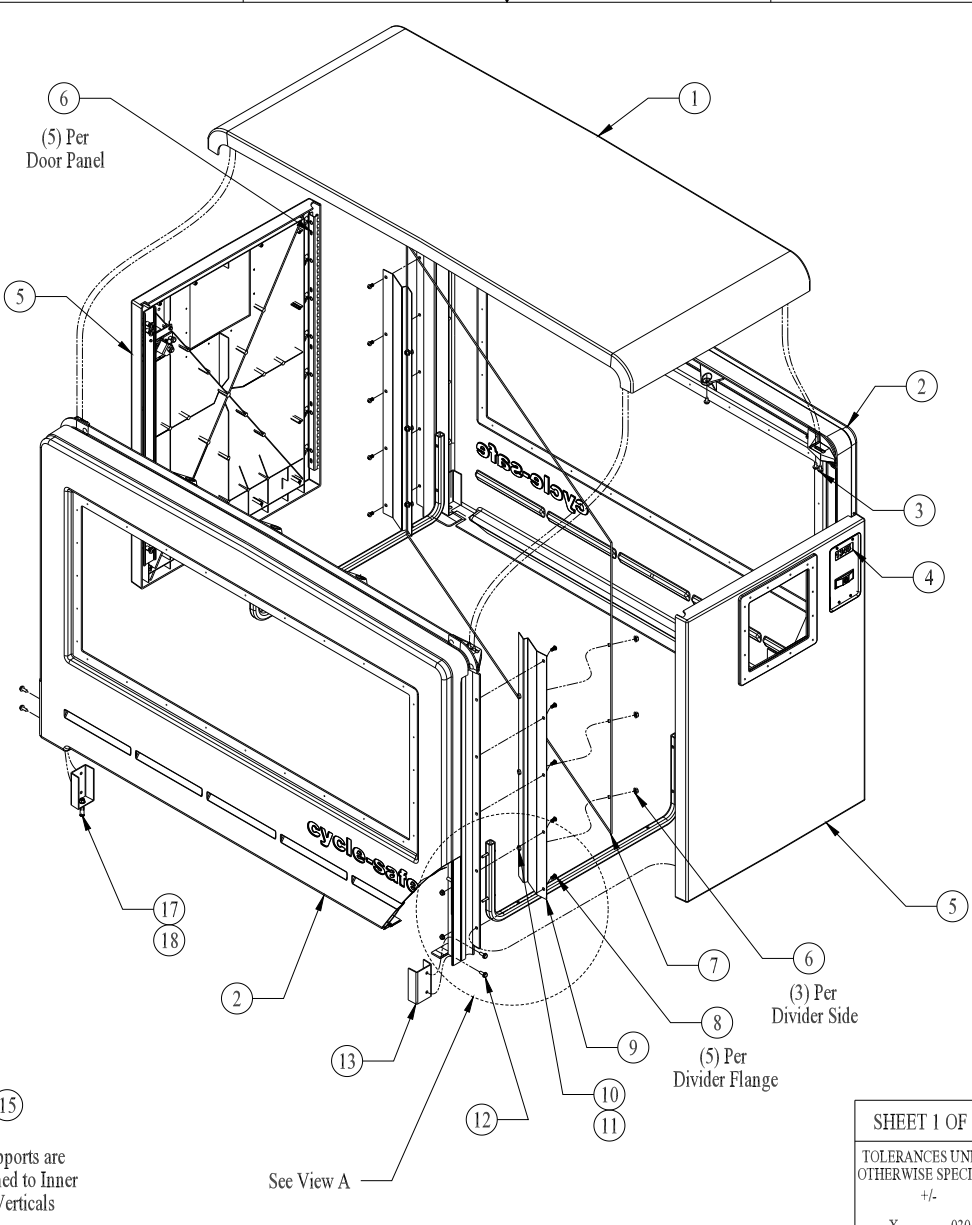

Door Supports are to be fastened to Inner Rib of Verticals

View A  
2:1

See View A

ITEM	QTY	DESCRIPTION	PART NO.
1	1	TOP PANEL	10301
2	2	END PANEL (VIEW-THRU)	10964
3	14	5/16"-18NC x 1-1/4" LG. SHMS	10222
4	1	NUMBER PLATE	10703
5	2	DOOR (LOWER) ASSEMBLY (VIEW-THRU)	10714
6	24	5/16"-18NC WHIZ NUT	10304
7	1	DIVIDER (POLY) PANEL	19566
8	10	5/16"-18NC x 3/4" LG. HHCS	10219
9	2	DIVIDER MOUNTING FLANGE	10207
10	6	5/16" FLAT WASHER	10218
11	6	5/16"-18NC x 1-1/4" LG. HHCS	10214
12	8	1/4"-20NC x 1-1/4" LG. SELF TAPPING SCREW	10217
13	4	LEVELING PLATE	10216
14	1	TORX BIT	10801
15	2	INTERIOR DOOR SUPPORT	10755
16	8	5/16"-18NC x 2" LG. HHCS	11106
17	4	3/8"-16NC x 1-7/8" ANCHOR BOLT	10211
18	4	3/8" S/S FLAT WASHER	10909

NOTES:

1. ALL MATERIALS MUST BE CLEAN AND FREE OF MILL LUBRICATION
2. ANY BLEMISHES OR RUST WILL NOT BE ALLOWED ON COMPLETED PRODUCTS

SHEET 1 OF 1		A	RELEASE FOR PRODUCTION	06/09/11
REV	DESCRIPTION	DATE		
TOLERANCES UNLESS OTHERWISE SPECIFIED:		PROPARK ~ VT (M02) LOCKER (LOWER) TIER		
+/-		 947 FOREST HILL AVE GRAND RAPIDS, MI 49546 www.cyclesafe.com		
.X	.030			
.XX	.010			
.XXX	.005			
ANGLE	1/2°	G.M.	04/27/10	
		R.E.S.	06/09/11	
		APPROVED	DATE	
REV	DESCRIPTION	QTY	PART NO.	REV
D	(VT) LOCKER (LOWER) TIER ASSEMBLY	10007		A

# Locker Assembly 2-Door {M02}

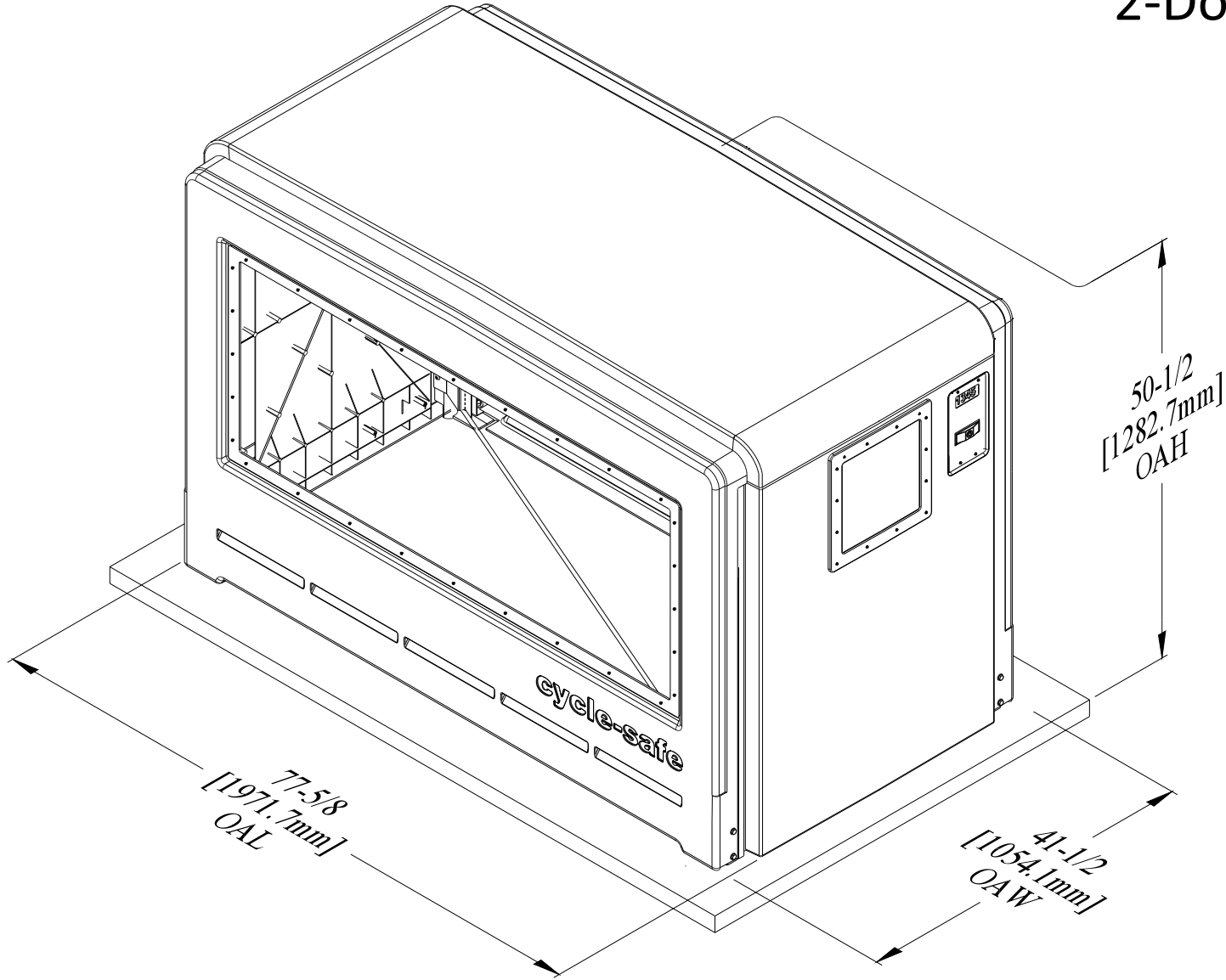

ProPark {VT}  
{View-Thru} Assembly {Dims}

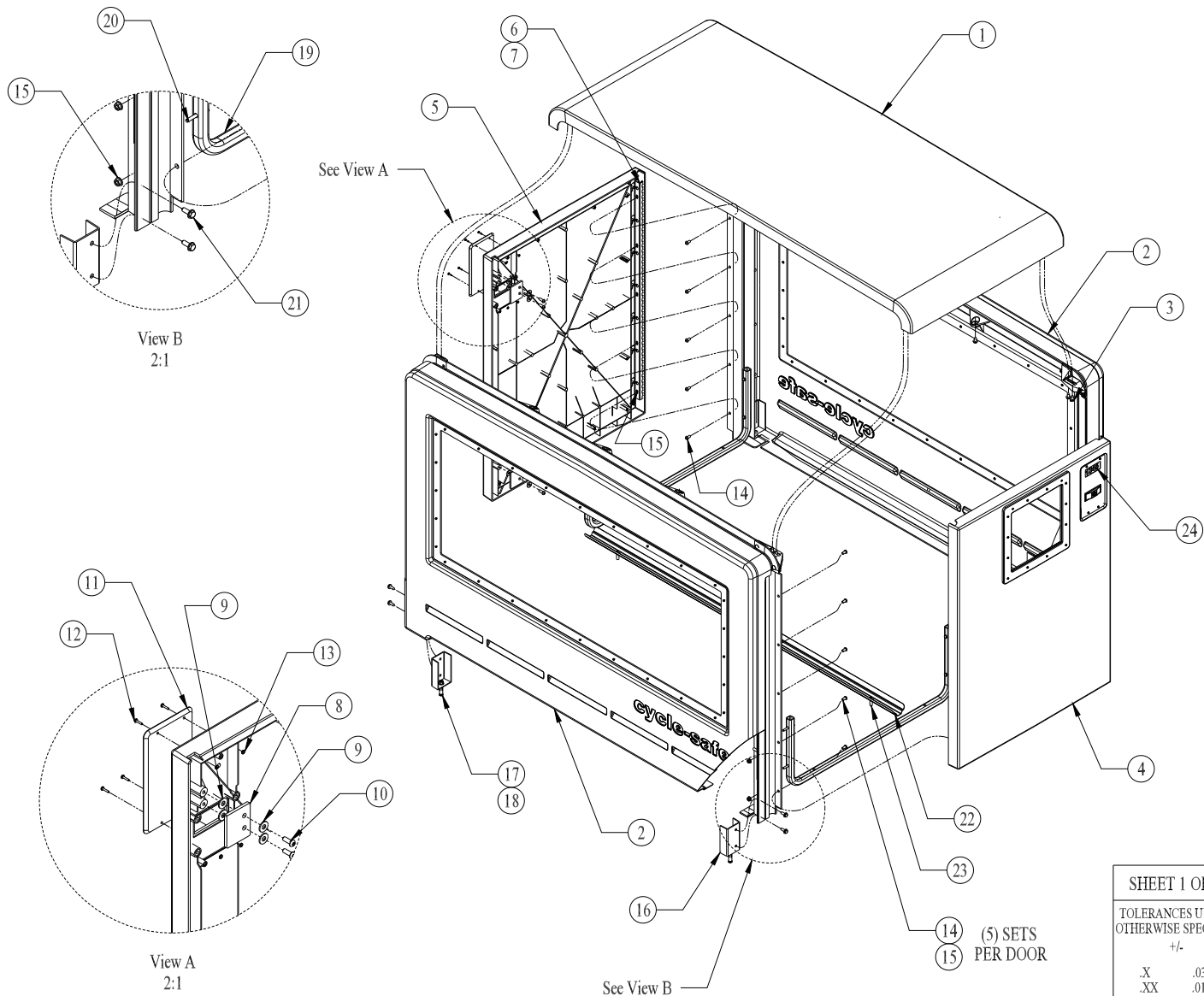

ITEM	QTY	DESCRIPTION	PART NO.
1	1	TOP PANEL	10301
2	2	END PANEL (VIEW-THRU)	10964
3	14	5/16"-18NC x 1-1/4" LG. SHMS	10222
4	1	DOOR (LOWER) ASSEMBLY (VIEW-THRU)	10714
5	1	DOOR (LOWER) PANEL (STANDARD)	10700
6	1	HINGE ASSEMBLY	10706
7	7	1/4-10NC x 1/2" PHILLIPS PAN HEAD SCREW	10705
8	2	STATIONARY LATCH	10742
9	8	7/16" ID x 15/16" OD S/S FLAT WASHER	10832
10	4	5/16-18NC x 2" FLANGE HEAD SCREW (ZINC)	10833
11	1	DOOR (THICK) COVER PLATE	11702
12	4	3/16" x 3/8" x 1/2" LG. S/S POP RIVET	10928
13	4	3/16" S/S FLAT WASHER	10929
14	10	5/16-18NC x 3/4" LG. HHCS (ZINC)	10219
15	18	5-16-18NC WHIZ NUT (ZINC)	10304
16	4	LEVELING PLATE	10216
17	4	3/8-16NC x 1-7/8" ANCHOR BOLT	10211
18	4	3/8" S/S FLAT WASHER	10909
19	2	INTERIOR DOOR SUPPORT	10755
20	8	5/16-18NC x 2" LG. HHCS (ZINC)	11106
21	8	1/4-20NC x 1-1/4" LG. SELF-TAPPING SCREW	10217
22	1	BIKE TRACK	10410
23	3	3/8-16NC LAG BOLT ASSEMBLY	10415
24	1	NUMBER PLATE	10703
25	1	T40 - TORX BIT	10801

NOTES:

1. ALL MATERIALS MUST BE CLEAN AND FREE OF MILL LUBRICATION
2. ANY BLEMISHES OR RUST WILL NOT BE ALLOWED ON COMPLETED PRODUCTS

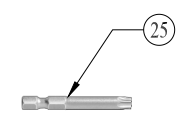

SHEET 1 OF 1		A	RELEASE FOR PRODUCTION	07/0912
REV	DESCRIPTION			DATE
TOLERANCES UNLESS OTHERWISE SPECIFIED:		PROPARK ~ VT {S01} (SINGLE-SIDED) LOCKER		
+/-		 947 FOREST HILL AVE GRAND RAPIDS, MI 49546 www.cyclesafe.com		
.X	.030			
.XX	.010			
.XXX	.005			
ANGLE	1/2°	R.E.S.	07/20/12	
		CHECKED	DATE	
		APPROVED	DATE	
SIZE	(VT) LOCKER (LOWER) TIER ASSEMBLY	10043		REV A

# Locker Assembly 1-Door {S01}

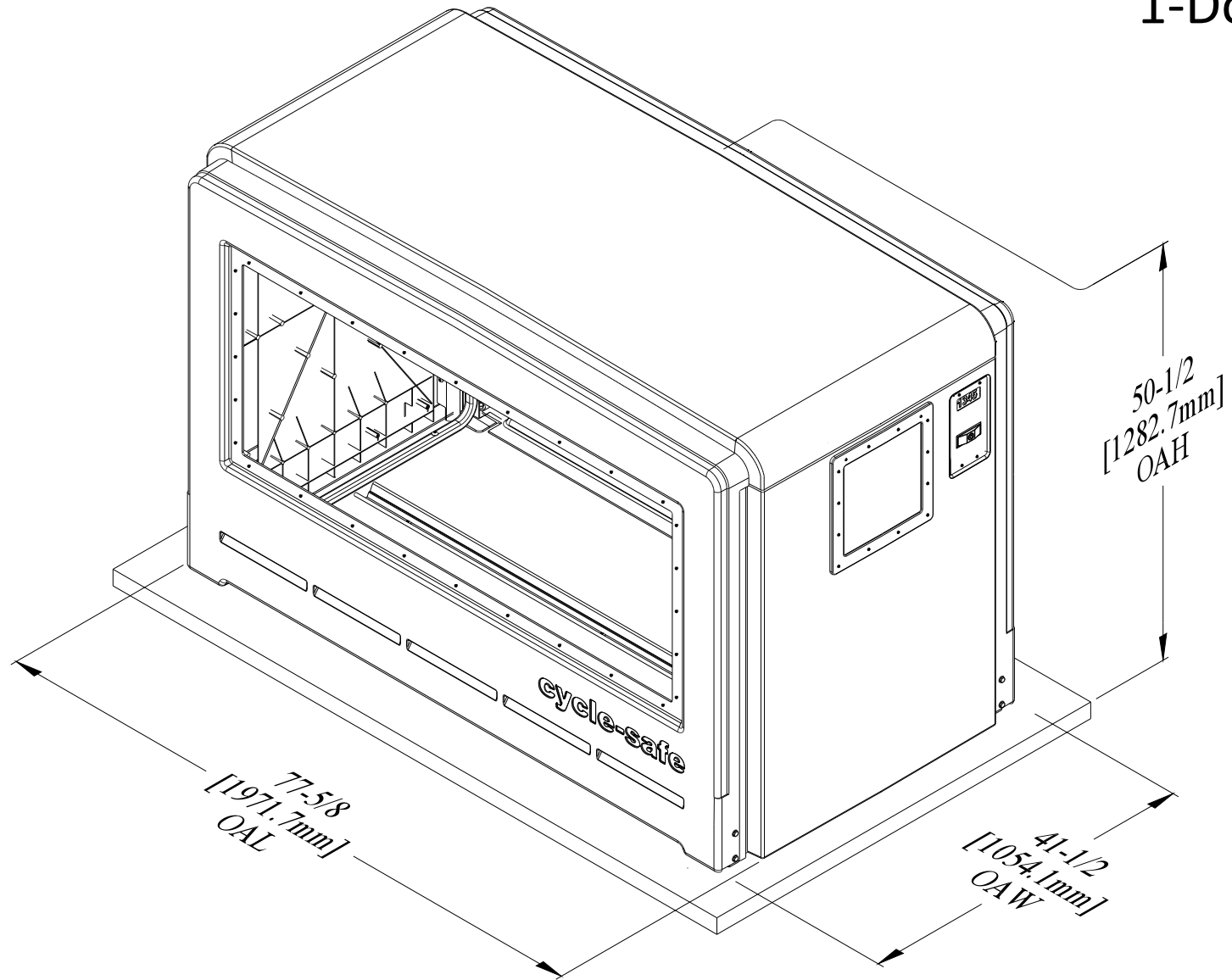

ProPark {VT}  
{View-Thru} Assembly {Dims}



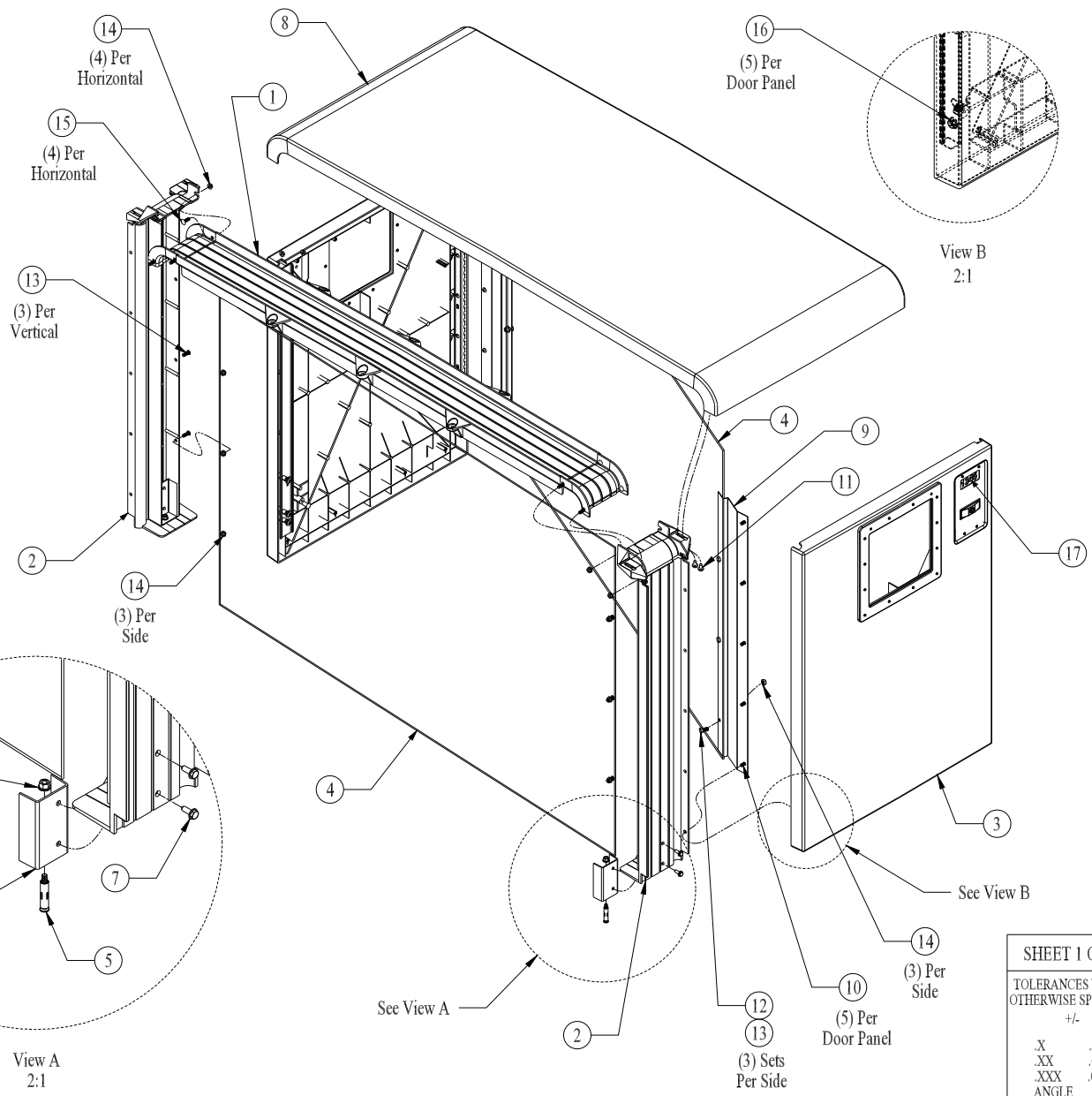

ITEM	QTY	DESCRIPTION	PART NO.
1	1	HORIZONTAL FRAME	10202
2	2	VERTICAL FRAME	10201
3	2	DOOR (LOWER) ASSEMBLY (VIEW-THRU)	10714
4	2	DIVIDER (POLY) PANEL	19566
5	2	3/8"-16NC x 1-7/8" ANCHOR BOLT	10211
6	2	LEVELING PLATE	10216
7	4	1/4"-20NC x 1-1/4" LG. SELF TAPPING SCREW	10217
8	1	TOP PANEL	10301
9	2	DIVIDER MOUNTING FLANGE	10207
10	10	5/16"-18NC x 3/4" LG. HHCS	10219
11	14	5/16"-18NC x 1-1/4" LG. SHMS	10222
12	12	5/16" FLAT WASHER	10218
13	12	5/16"-18NC x 1-1/4" LG. HHCS	10214
14	24	5/16"-18NC WHIZ NUT	10304
15	8	5/16"-18NC X 1" LG. CARRIAGE BOLT	10208
16	2	3/8" S/S FLAT WASHER	10909
17	2	NUMBER PLATE	10703
18	1	TORX BIT	10801

NOTES:

1. ALL MATERIALS MUST BE CLEAN AND FREE OF MILL LUBRICATION
2. ANY BLEMISHES OR RUST WILL NOT BE ALLOWED ON COMPLETED PRODUCTS

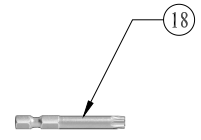

SHEET 1 OF 1		A	RELEASE FOR PRODUCTION	06/29/11		
REV	DESCRIPTION	DATE				
TOLERANCES UNLESS OTHERWISE SPECIFIED:		PROPARK ~ DV (M02) LOCKER (LOWER) ADDER				
+/-		<b>Cycle Safe</b> 947 FOREST HILL AVE GRAND RAPIDS, MI 49546 www.cycleSAFE.com				
.X	.030				R.E.S.	06/29/11
.XX	.010				CHECKED	DATE
.XXX	.005				APPROVED	DATE
ANGLE	1/2°					
REV	D	(VT) LOCKER (LOWER) ADDER	10056	REV A		

# Locker Assembly 4-Door {M04}

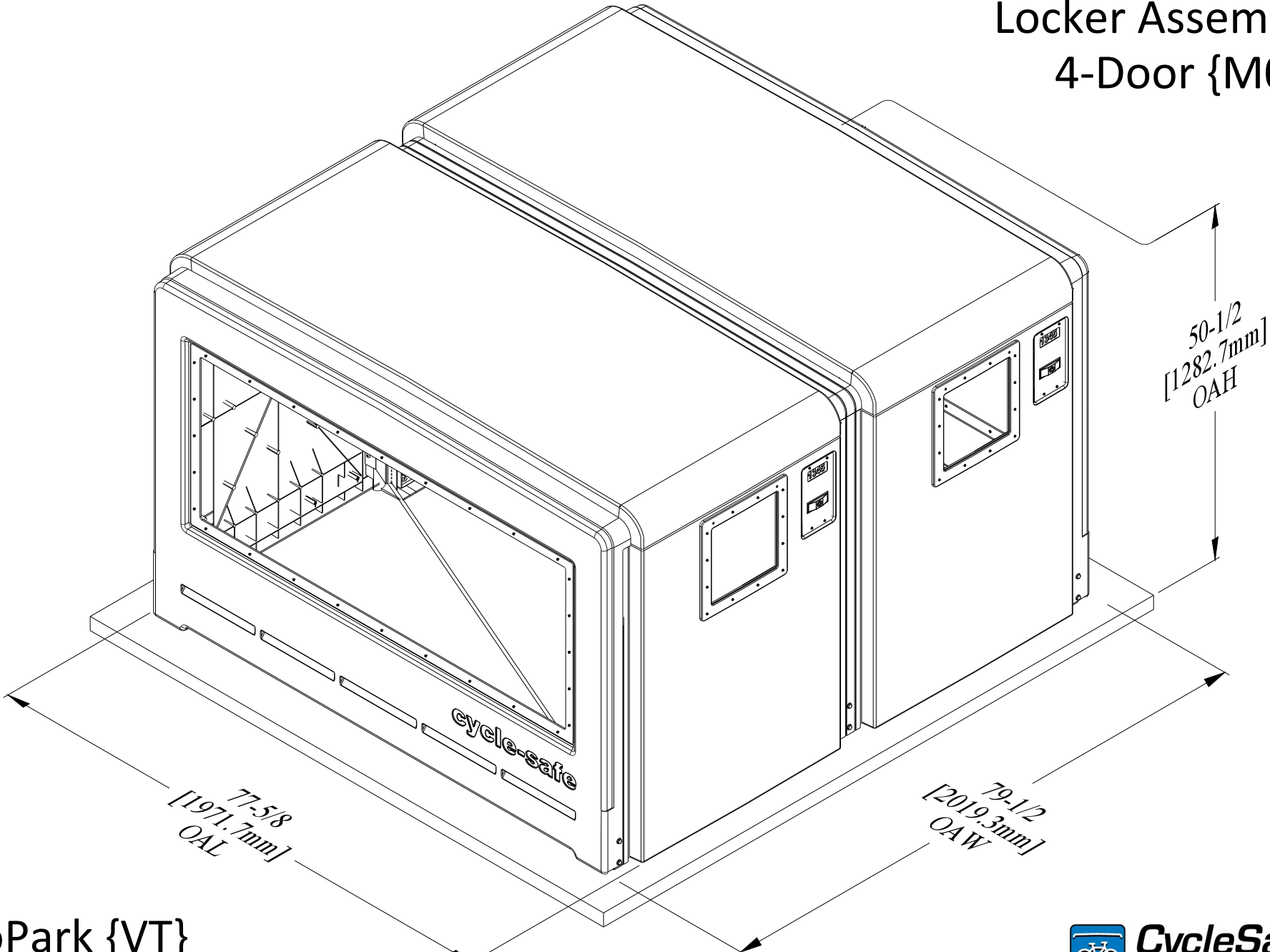

ProPark {VT}  
{View-Thru} Assembly {Dims}

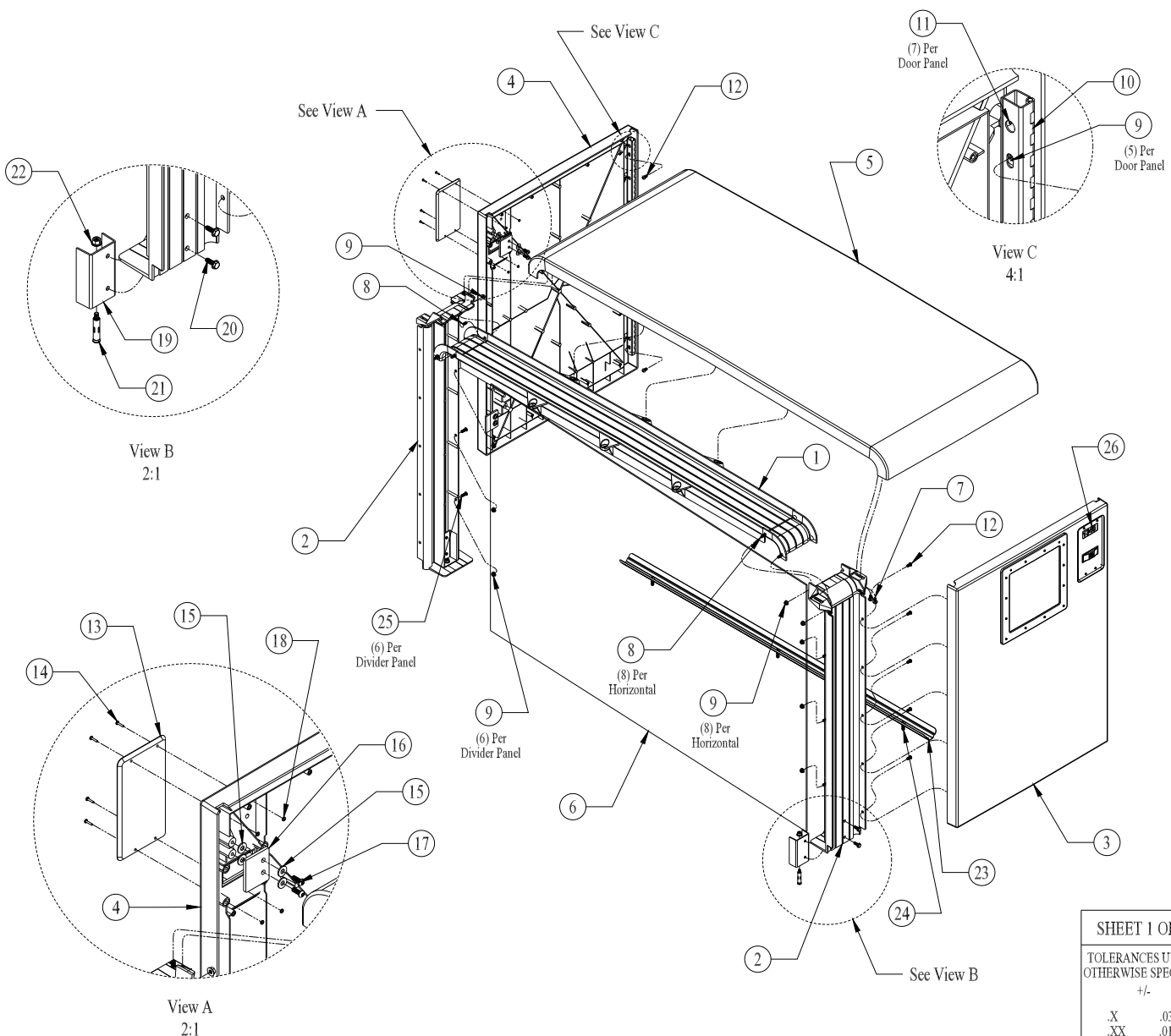

ITEM	QTY	DESCRIPTION	PART NO.
1	1	HORIZONTAL FRAME	10202
2	2	VERTICAL FRAME	10201
3	1	DOOR {LOWER} ASSEMBLY {VIEW-THRU}	10714
4	1	DOOR {LOWER} PANEL {STANDARD}	10700
5	1	TOP PANEL	10301
6	1	DIVIDER { POLY} PANEL	19566
7	14	5/16-18NC x 1-1/4" LG. SHMS {ZINC}	10222
8	8	5/16-18NC x 1" LG. CARRIAGE BOLT	10208
9	24	5/16"-18NC WHIZ NUT {ZINC}	10304
10	1	HINGE ASSEMBLY	10706
11	7	1/4-10NC x 1/2" PHILLIPS PAN HEAD SCREW	10705
12	10	5/16-18NC x 3/4" LG. HHCS	10219
13	1	DOOR {THICK} COVER PLATE	11702
14	4	3/16" x 3/8" x 1/2" LG. S/S POP RIVET	10928
15	8	7/16" ID x 15/16" OD S/S FLAT WASHER	10832
16	2	STATIONARY LATCH	10742
17	4	5/16-18NC x 2" FLANGE HEAD SCREW {ZINC}	10833
18	4	3/16" S/S FLAT WASHER	10929
19	2	LEVELING PLATE	10216
20	4	1/4-20NC x 1-1/4" LG. SELF-TAPPING SCREW	10217
21	2	3/8-16NC x 1-7/8" LG. ANCHOR BOLT	10211
22	2	3/8" S/S FLAT WASHER	10909
23	1	BIKE TRACK	10410
24	3	3/8-16NC LAG BOLT ASSEMBLY	10415
25	6	5/16-18NC x 1-1/4" LG. HHCS {ZINC}	10214
26	1	NUMBER PLATE	10703
27	1	TORX BIT	10801

NOTES:

1. ALL MATERIALS MUST BE CLEAN AND FREE OF MILL LUBRICATION
2. ANY BLEMISHES OR RUST WILL NOT BE ALLOWED ON COMPLETED PRODUCTS

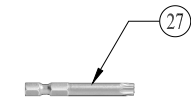

SHEET 1 OF 1		A	RELEASE FOR PRODUCTION	08/2012		
REV	DESCRIPTION	DATE				
TOLERANCES UNLESS OTHERWISE SPECIFIED:		PROPARK ~ VT {S01} LOCKER {LOWER} ADDER				
+/-		<b>Cycle Safe</b> 947 FOREST HILL AVE GRAND RAPIDS, MI 49546 www.cycleSAFE.com				
.X	.030				BOB SLYH	08/20/12
.XX	.010				CHECKED	DATE
.XXX	.005				APPROVED	DATE
ANGLE	1/2°					
REV	D	(SINGLE-SIDED) LOCKER {LOWER} ADDER	10045	REV A		

# Locker Assembly 2-Door {S02}

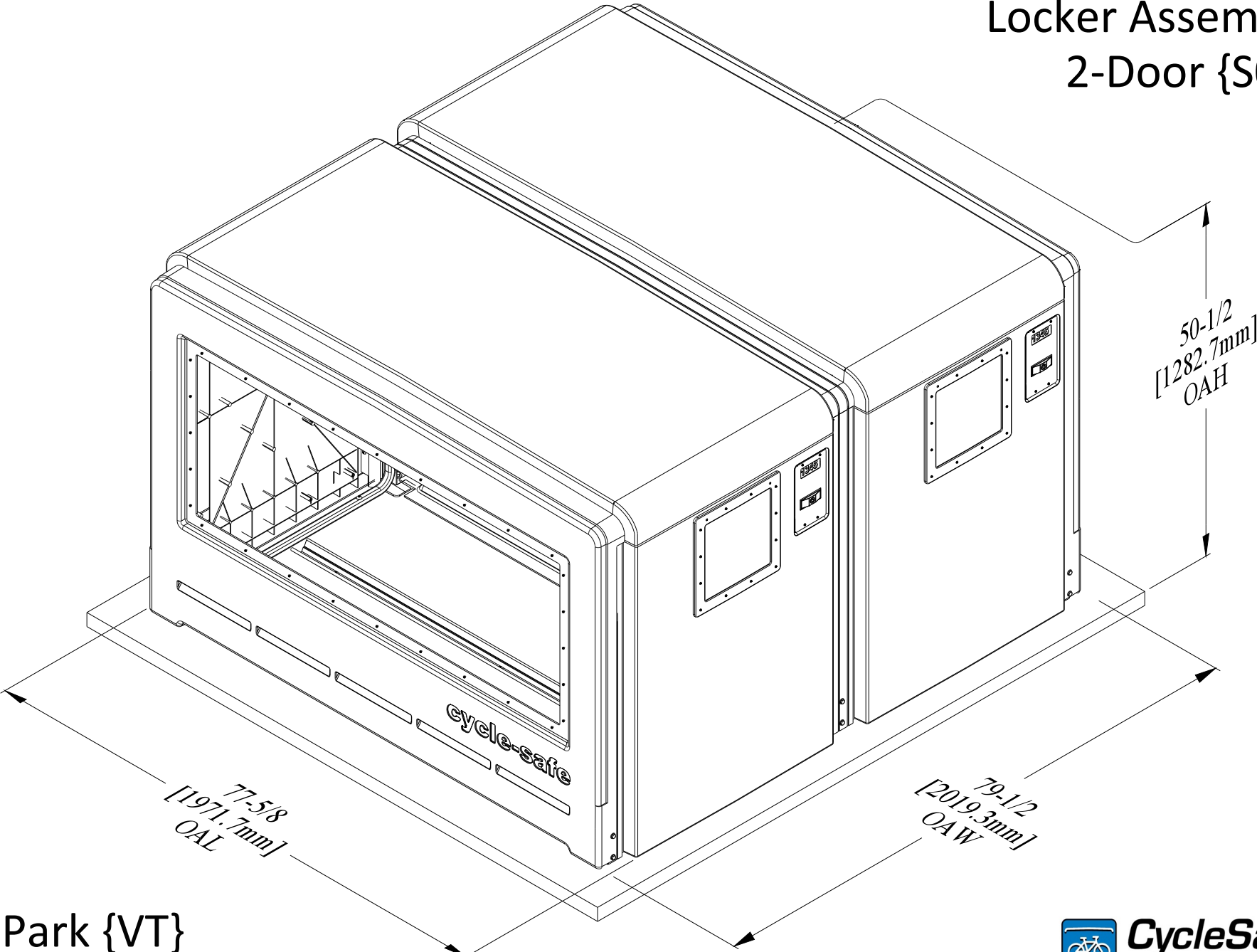

ProPark {VT}  
{View-Thru} Assembly {Dims}